

MODULAR CONVEYOR BELTS FOR THE FOOD INDUSTRY

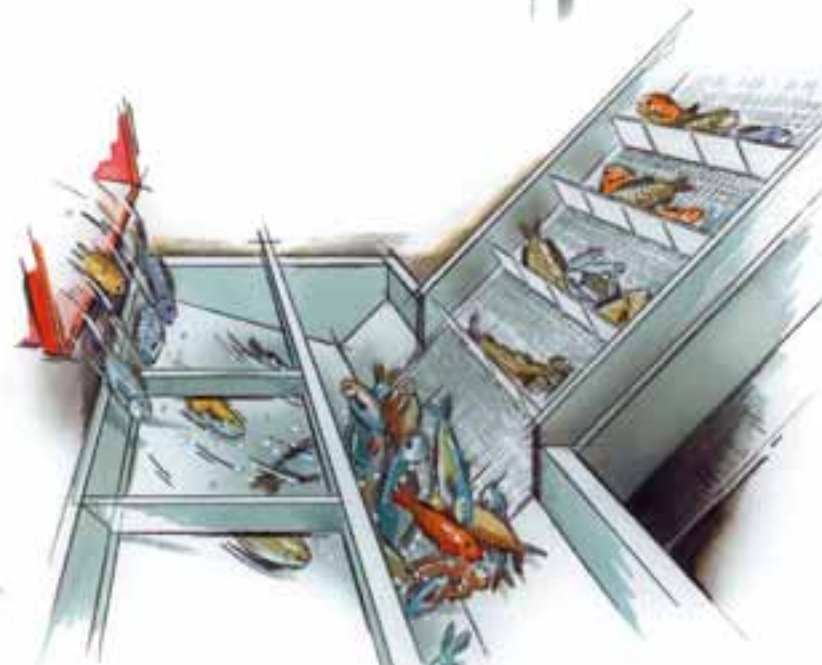
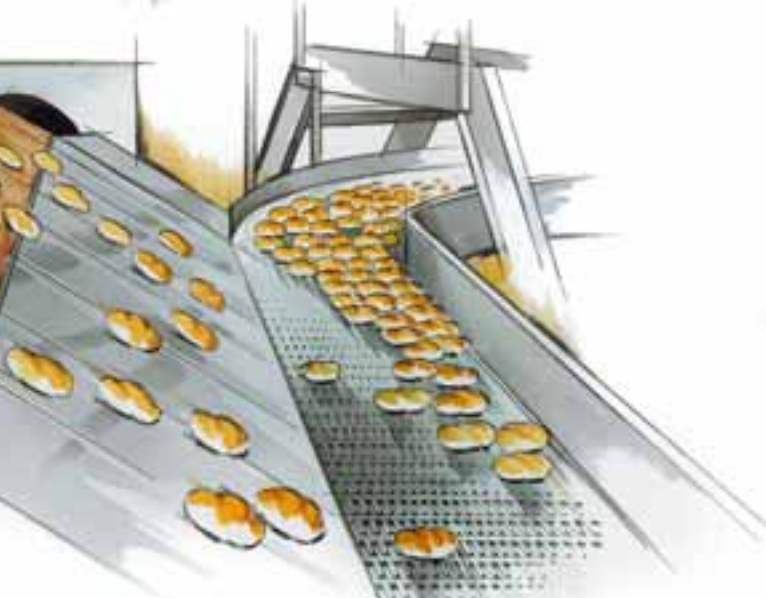

CONTENTS

Introduction Page 3

Belt programme 4-18

Applications

		Meat	Poultry	Fish	Fruit	Vegetables	Bakery	Confectionery	Packed products
505 Flex	4/5								
1255 Flex/Straight	6/7								
1255 SuperGrip	6/7								
1505 Flat Top	8/9								
1506 Flush Grid	8/9								
1505 SuperGrip	8/9								
1000 Flat Top	10/11								
1000 Flush Grid	10/11								
1000 SuperGrip	10/11								
6391 Flush Grid	12/13								
6392 Flush Grid	12/13								
2015 Solid Top	14/15								
2016 Perforated Top	14/15								
2011 Textured Top	14/15								
5998 Flush Grid	16/17								
1221 RC	18								
1221 ROT	18								

Materials 19

Addresses 20



PLASTIC MODULAR CONVEYOR BELTS FOR THE FOOD INDUSTRY

To meet the specific requirements of the food manufacturing industry, Rexnord has a huge programme of plastic modular conveyor belts available. Having vast experience in a variety of industries we can guarantee reliable delivery of the tailor-made belts within a few days. All polypropylene, polyethylene and acetal materials listed in this brochure are suited for direct contact with food.



TYPICAL APPLICATION OF A MCC FOOD BELT IN A CHICKEN SLAUGHTER HOUSE

These belts can be utilised in boning lines, chicken plants, abattoirs, fruit and vegetables industries, fish processing, bakery lines and a wide variety of packaging applications. You can choose the belt you need from the table on page 2 and by reading the benefits and applications on the left pages of each series.

All belts have been designed with cleanability in mind. However, practice learns that some areas are difficult to reach while cleaning and that wear patterns or damage of the belt can make proper cleaning more difficult. For this reason we have gone one step further in hygiene: as a standard, most of the belts in the programme are equipped with



Though not a replacement for good hygienic practices, Microban antibacterial protection ensures improved hygiene, specially in between regular cleaning operations. Microban is safe, durable and effective.

By penetrating the cell wall of bacteria, Microban inhibits the growth of most common food poisoning bacteria, such as E.coli 0157, Salmonella, Listeria, Staphylococcus Aureus, Campylobacter, etc., which can cause contamination in the reference to food.

Independent laboratory tests have proven Microban to be effective throughout the lifetime of the product. Because it is built-in, it is working all-over, all the time, even in areas damaged by knife cuts or scratches.

The European Union Scientific Committee for Food (SCF) has found the active agent in Microban technology to be safe in food contact uses; in the United States the Environmental Protection Agency (EPA) has approved it for use in conveyor belts.

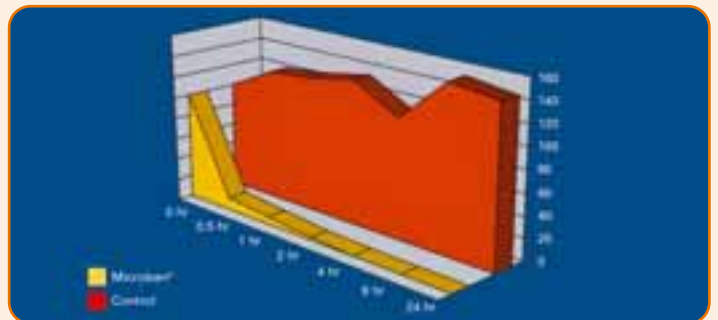

BACTERIA E.COLI 0157 ON MICROBAN INCORPORATED PLASTIC COMPARED TO IDENTICAL UNTREATED PLASTIC

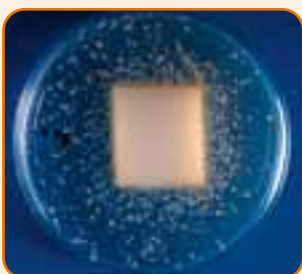

WITHOUT PROTECTION;
GROWTH OF BACTERIA ON
AND AROUND THE PRODUCT



WITH ;
ABSENCE OF BACTERIA ON
AND AROUND THE PRODUCT

More and more internationally respected companies are using Microban in products such as boots, food containers, chopping boards, knives, workwear and so on. The Rex and MCC Microban programme features several straight running and sideflexing belts. The Microban technology is also available in combination with other products in our programme, such as Marbett feet, wearstrips and bearings.

The materials mentioned in this brochure are intended for European customers. Please contact Rexnord for products available in other countries.

505 SERIES FLEX BELTS

505 Series flex belts are suitable for sideflexing transport of small to medium size, packed or non-packed, products that require a small transfer. The 505 belt has a 1/2 inch pitch, the smallest available in the world. The open area is 10%.



505 SIDEFLEXING BELT FOR SMALL PACKAGING APPLICATIONS

TYPICAL APPLICATIONS

505 Flex belts can be used in curve sections in combination with small packed products, small trays with chicken or meat, packed snack food, boxes with ice-cream, salad bags etc. They are also very suitable for unpacked but vulnerable products requiring careful handling on inline transfers, such as bread rolls, small meat or chicken filets, candy-bars, etc.

A combination with 1500-series belts in straight conveyors is very well possible.

AND...

The belts will be supplied in standard lengths of 10 feet (3.048 m).

Two versions of curve guiding profiles are available:

MCC 3500 special polyamide (code nr. 800.00.01, length 2 m) for high load and high speed applications and the FDA-approved MCC 3600 polyester type for conveyors with direct food contact (code nr. 800.00.13, length 2 m).

505 belts without positrack are optionally.

As a standard, WSA 505 RBP belts are equipped with



BENEFITS

✚ Cleanability

The chamfered Positrack lugs hold down the 505 belt in the curve, so that no U-shaped profiles or profiles on top of the belt are needed. This allows the belt to be easily lifted from the curve for cleaning purposes.

✚ Optimum use of floor space

The inside radius of the belts can be as small as two times the width, reducing the required space for the conveyor.

✚ Superior product handling

The surface design with small gaps and the minimal chordal action result in the best possible stability of the products.

✚ Easy installation and maintenance

Due to the modular design and the rod retention clips, the belts can be fitted and removed in a few seconds.

✚ Fewer drives

With this belt you do not only cover the bend, but you can also extend the conveyor by adding straight sections, so saving drives.

✚ Safety

Openings in the belt surface have been minimised to prevent any object getting caught in the belt. Because no hold-down profiles are required in the curve, dangerous situations at the infeed of the curve are prevented.

✚ Excellent guiding

Because the belt is guided at the outside radius in the curve, it is running very smoothly. The Positrack lugs on both sides of the belt are not only used for guidance in the curve, they also prevent lateral movement in the straight sections. Therefore profiles locking the belt on the side are unnecessary.



EGG-ROLLS SMOOTHLY CONVEYED ON 505



POSITRACK GUIDING LUGS



CURVE GUIDING PROFILE



ROD RETENTION BY EASY CLIPS

505 FLEX BELTS

Belt material	Colour	Rod material	Working load		Temperature range (°C)		Belt weight kg/m ²	Inside sideflex radius	Backflex radius (min)
			straight	curve	dry	wet			
			N/m	N					mm
WSA Acetal BSA Acetal	White Blue	special reinforced plastic	15000	1300	-40 up to 80	up to 65	9.0	minimal 2 times belt width	15.0

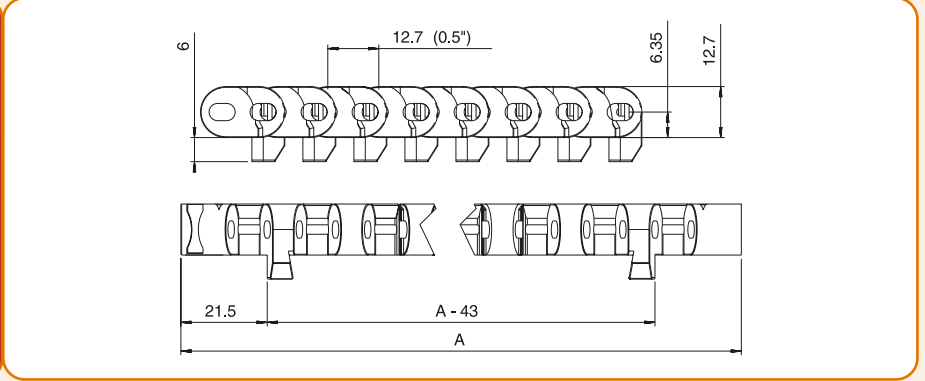
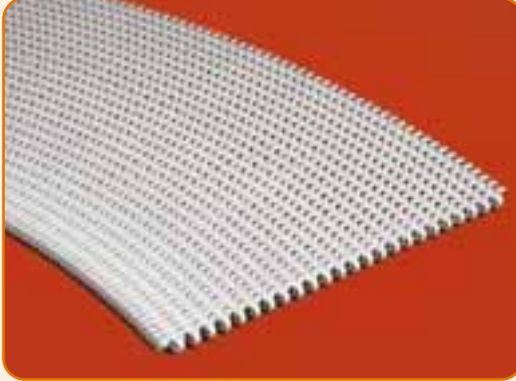

SPROCKETS FOR 505 SERIES

Number of teeth	Bore B	Code number	Pitch diameter E	Outside diameter F	Hub width A
	mm				
28	30 x 30	894.25.27	113.4	113.4	16.5
28	40 x 40	894.25.21			
28	Ø30	894.25.17			
28	Ø40	894.25.11			

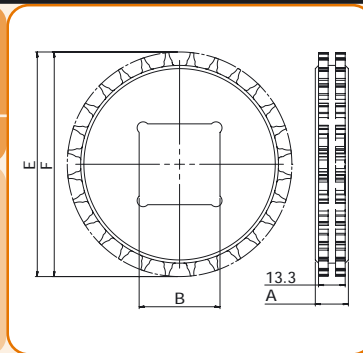

All sprockets are one-piece, machined and made of polyamide. Moulded split sprockets are also available. The number of sprockets needed and construction details can be found in our Engineering Manual for sideflexing belts.

HOW TO ORDER THIS BELT?

To make a description of the belt you require, please choose from the options listed in the 2nd column of the table below for every part:

Material	WSA or BSA	See table above and page 19
Belt type	505	
Width (A)	KM-... (in mm)	Standard nominal widths begin at 255 mm, with 85 mm increments, or optionally 17 mm

For example:

- WSA 505 KM-340 is a 505 flex belt made of white acetal with Microban, width 340 mm.

If the belt or the sprocket (size, bore or material) you require is not described in these tables, please send us a detailed drawing or ask our Technical Support department for advice.

1255 SERIES

1255 Series belts are the most versatile ones. They can be used for both straight running and sideflexing conveyors carrying larger packed or non-packed products. This belt can be equipped with flights and therefore it is suitable for inclined conveyors as well. The 1255 belt has a 1/4 inch pitch and is intended for medium load applications. The open area is 39%.



1255 SIDEFLEXING BELT FOR UNPACKED POULTRY APPLICATIONS

TYPICAL APPLICATIONS

1255 Flex belts can be used for curve sections, straight sections and inclined conveyors, such as elevators. They are suitable for conveying medium size packed products, such as boxes with frozen fish and crates with meat, bagged salad, bagged meat or chicken and frozen bagged vegetables, etc. Other applications are medium to larger sized unpacked products such as bread, whole chicken, large pieces of meat, etc.

AND...

The belts will be supplied in standard lengths of 10 feet (3.048 m). Two versions of curve guiding profiles are available: MCC 3500 special polyamide (code nr. 800.00.10, length 1.8 m) for high load and high speed applications and the FDA-approved MCC 3600 polyester for conveyors with direct food contact (code nr. 800.00.11, length 2 m).

1255 Belts without positrack or with tabs are optionally. As a standard, all 1255 belts are equipped with



BENEFITS

Superior cleanability

The modules are flush and well rounded and because of the slotted holes in the hinge eyes dirt can not build up. The chamfered Positrack lugs hold down the 1255 belt in the curve, so that no U-shaped profiles or profiles on top of the belt are needed. This allows the belt to be easily removed from the curve for cleaning purposes.

Excellent guiding

The belt runs very smoothly because it is guided at the outside radius of the curve. The Positrack lugs on both sides of the belt are not only used for guidance in the curve, they also prevent lateral movement in the straight sections.

Versatile

A high standardisation level can be achieved because the 1255 belt is suitable for straight, curved and inclined conveyors. This means there is one conveyor design, one sprocket type and a reduced number of components in the conveyor.

Optimum use of floor space

The inside radius of the belts can be as small as two times the width, reducing the required space for the conveyor.

Easy installation and maintenance

Due to the modular design and the rod retention by eccentric hinge eyes, the belts can be fitted and removed in a few seconds.

Safety

Openings in the belt surface have been minimised to prevent any object getting caught in the belt. Because no hold-down profiles are required in the curve, dangerous situations at the infeed of the curve are prevented.



PIZZAS SMOOTHLY CONVEYED ON 1255



POSITRACK GUIDING LUGS



FLIGHT FOR ELEVATING



CURVE GUIDING PROFILE



ROD RETENTION BY ECCENTRIC HINGE EYES

1255 FLEX BELTS

Belt material	Colour	Rod material	Working load		Temperature range (°C)		Belt weight	Inside sideflex radius	Backflex radius (min)
			straight	curve	dry	wet			mm
			N/m	N			kg/m ²		
WLA Polyethylene	White	PBT	7000	1000	-40 up to +35		5.5	minimal 2 times belt width	25.0
BLA Polyethylene	Blue		7000	1000	-40 up to +35		5.5		
WHA Polypropylene	White		11000	1200	4 up to 80	4 up to 50	5.2		
WSA Acetal	White		22000	2000	-40 up to +80	up to 50	8.0		
BSA Acetal	Blue		22000	2000	-40 up to +80	up to 50	8.0		

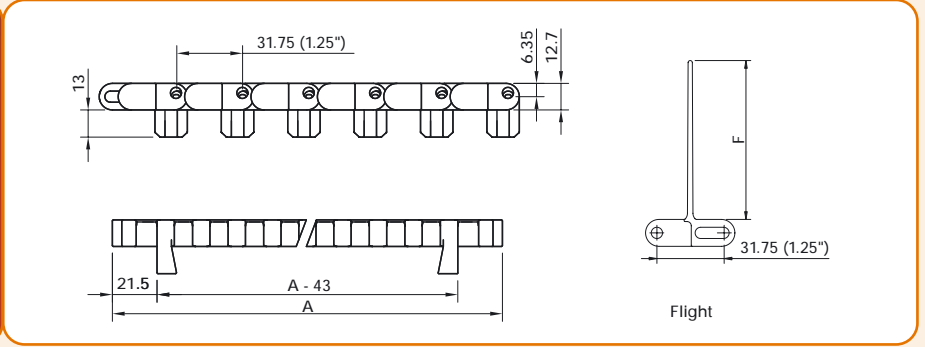
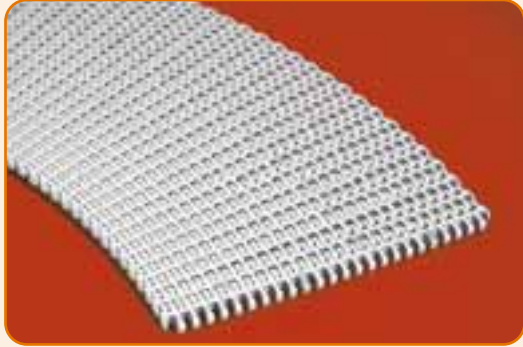

SPROCKETS FOR 1255 SERIES

Number of teeth	Bore	Code number	Pitch diameter E	Outside diameter F	Hub width A
	B				
		mm	mm	mm	mm
8	25x25	894.67.46	83.0	85.4	15.0
8	Ø30	894.67.37			
10	40x40	894.59.41	102.8	106.6	
10	Ø30	894.59.37			
13	40x40	894.63.41	132.7	137.5	
13	Ø40	894.63.31			
15	40x40	894.61.41	152.7	158.1	
15	Ø40	894.61.31			
16	40x40	894.65.41	162.8	168.3	
16	Ø40	894.65.31			

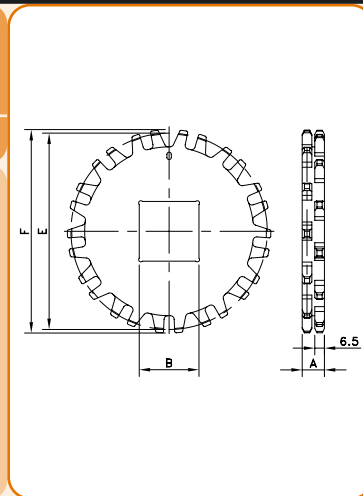

All sprockets are one-piece, machined and made of polyamide. Machined split sprockets are also available.

The number of sprockets needed and construction details can be found in our Engineering Manual for sideflexing belts.

HOW TO ORDER THIS BELT?

To make a description of the belt you require, please choose from the options listed in the 2nd column of the table below for every part:

Material	WLA BLA WHA WSA or.BSA	See table above and page 19
Belt type	1255 1255 SG	SG for SuperGrip for incline (only in WHA and WSA material)
Width (A)	KM-.. (in mm)	Standard nominal widths begin at 255 mm, with 85 mm increments, optional 17 mm
Height of flights	F3 H.. (in mm)	for standard height of 3" (76.2 mm) for special heights
Pitch between flights	T..P	Flights on every .. th row
Flight side-indent	N.. (in mm)	Minimal side-indent 51 mm with increments of 17 mm; side-indent is the distance from the side of the belt to the side of the flight

For example:

- BLA 1255 KM-425 is a 1255 flex belt made of blue polyethylene with Microban, width 425 mm.
- WHA 1255 KM-510 F3 T8P N51 is a 1255 flex belt made of white polypropylene with Microban, width 510 mm, 3" high flights on every 8th row, at 51 mm from the sides.

If the belt or sprocket (size, bore or material) you require is not described in this table, please ask our Technical Support for advice.

1500 SERIES

1500 Series Flat Top (1505) and Flush Grid (1506) belts are particularly suitable for transport of packed and fresh products requiring small transfers. The 1505 and 1506 belts have a 15 mm pitch. The open area of the 1506 is 26%.



TRANSFER OF CANNED FOOD FROM 1505 FLAT TOP BELT TO 1000 FLUSH GRID BELT

BENEFITS

Compact in-line transfers

The 15 mm pitch allows for a very compact inline transfer. Most 1500 series food applications require no dead-plate at all. The special designed bottom of the module virtually eliminates the chordal action and ensures a perfect product handling, even for vulnerable products.

Solid, bi-directional drive

The design of the 1500 series sprockets and modules ensures a perfect and reliable drive, better than that of any other small pitch belt.

Compact conveyor design

In combination with the 7-teeth sprocket a very compact drive construction can be obtained, still using a standard end drive. The combination is ideally suited for in- and outfeeds of food processing machines.

Easy installation and maintenance

Due to the modular design and the rod retention clips, the belts can be fitted and removed in a few seconds.

TYPICAL APPLICATIONS

1505/1506 Belts can be used in straight sections in combination with small packed products, small trays with chicken or meat, packed snacks, boxes with ice-cream, salad bags etc. They are also very suitable for unpacked but vulnerable products requiring careful handling on inline transfers, such as pan-cakes, bread rolls, pizzas, fish fillets, hamburgers and other small or vulnerable products that require a careful head-to-tail transfer. A combination with 505-series flexbelts in curved conveyors is very well possible.

AND...

The belts will be supplied in standard lengths of 3 meters. If the belt or sprocket (material, bore or size) you require is not described in the table, please ask our Technical Support for advice.

As a standard, all 1505/1506 belts are equipped with



BREAD-ROLLS AND DONUTS SMOOTHLY CONVEYED ON 1506



SUPERGRIP FOR INCLINE



FLIGHT



SIDE GUARDS



PIN RETENTION BY EASY CLIPS

1505 FT/1506 FG BELTS

Belt material	Colour	Rod material	Working load	Temperature range (°C)		Belt weight		Backflex radius (min) mm
				dry	wet	kg/m ²		
						1505	1506	
WLA Polyethylene	White	PBT	2800	-40 up to 35		4.8	4.1	16.0
BLA Polyethylene	Blue	Polyethylene	2800	-70 up to +35		4.8	4.1	
WHA Polypropylene	White	PBT	7300	4 up to 80	4 up to 50	4.5	3.9	
WSA Acetal	White	PBT	13200	-40 up to +80	-40 up to +50	6.2	5.4	
BSA Acetal	Blue	PBT	13200	-40 up to +80	-40 up to +50	6.2	5.4	

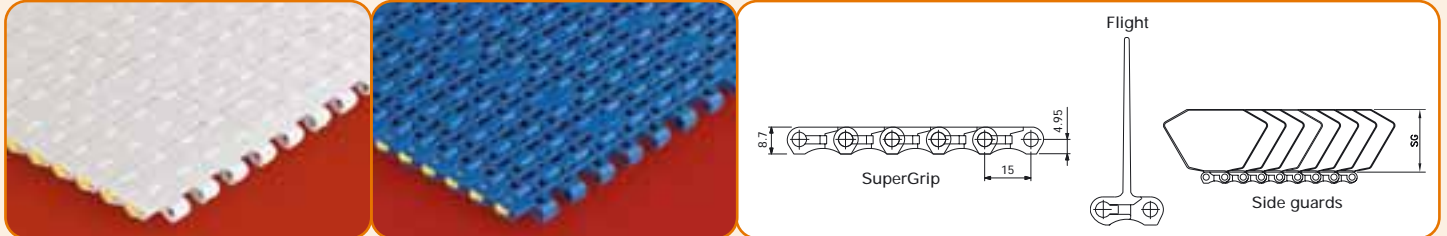

SPROCKETS FOR 1500 SERIES

Number of teeth	Bore	Code number	Pitch diameter E	Outside diameter F	Hub width A
	B				
24	40 x 40	114-3405-2	114.9	116.0	40.0
32	40 x 40	114-3406-2	153.0	155.0	
32	60 x 60	114-3406-3			

The image includes a technical drawing of a sprocket showing dimensions: L (pitch circle diameter), E (pitch diameter), F (outside diameter), B (bore diameter), and A (hub width). A photo shows a white sprocket with 24 teeth.

All sprockets are one-piece, machined and made of white polyethylene. For most applications, 1 sprocket is recommended for every 3" (76.2 mm) belt width.

MINI-SPROCKETS FOR 1500 SERIES

Number of teeth	Bore	Code number	Pitch diameter E	Outside diameter F	Hub width A
	B				
7 drive	20	614-301-3	34.6	33.1	18.5
7 idler	20	614-301-4			

The image includes a technical drawing of a mini-sprocket showing dimensions: 5.8 (pitch diameter), 13 (pitch diameter), 16.5 (pitch diameter), B (bore diameter), and A (hub width). A photo shows a black mini-sprocket mounted on a shaft.

The 7-teeth sprockets are one-piece, moulded and made of black reinforced, not FDA-approved polyamide. The drive sprocket has an integrated key. For most applications, 2 sprockets are recommended for every 3" (76.2 mm) belt width. The code number means a set of 2 sprockets and 2 retaining rings.

HOW TO ORDER THIS BELT?

To make a description of the belt you require, please choose from the options listed in the 2nd column of the table below for every part:

Material	WLA BLA WHA WSA BSA	See table above and page 19
Belt type	1505 FT 1506 FG 1505 SG 1505 SGS	FT for FlatTop FG for Flush Grid SG for SuperGrip (only in WHA and WSA material) SGS for SuperGrip with Side indent of 44 mm (only in WHA and WSA)
Width	KI.. (in inches)	Standard nominal widths of these belts begin at 3" (76.2 mm), with 3" increments, or optionally 3/4" (19 mm). NOTE: 3 3/4" is impossible. SuperGrip belts start from 85 mm with 85 mm increments; for inch versions of SuperGrip ask Technical Support.
Height of flights	F2 F1 H.. (in mm)	For standard height of 2" (50.8 mm) For standard height of 1" (25.4 mm) For special heights
Pitch between flights	T..P	Flights on every .. th row
Flight side-indent	N.. (in inches)	Minimal side-indent (distance from side belt to flight) 1 7/8" (48 mm) with 3/4" (19 mm) increments
Height of side guards	SG2 SG1	Standard height 2" (50.8 mm) Standard height 1" (25.4 mm)

1000 SERIES

1000 Series Flat Top and Flush Grid belts are suitable for virtually any general conveying application. They can be equipped with flights. The high friction SuperGrip version is intended for inclining and declining applications. The 1000 belts have a 1 inch pitch. The open area of the 1000 FG is 40%.



1000 FLUSH GRID BELT FOR BAKERY APPLICATIONS

BENEFITS

Strong and rigid belt design

Due to the symmetrical module design and the large number of hinge eyes, the belt is very rigid, strong and economical for use in many general food handling applications.

Easy installation and maintenance

Due to the unique 2-module system and the quick access to the rods because of the clip system, the belt can be fitted and removed from the conveyor easily for cleaning and maintenance.

Good cleanability

The Flush Grid design combines a large open area with an excellent cleanability.

Precise positioning

In combination with optional Positrack lugs (only available in Acetal belts) the belts can be guided accurately. This prevents lateral movement of the belt in straight sections and allows for a hygienic conveyor design.

Inclined or stop belt applications

The high friction SuperGrip modules in the 1000-series offer unsurpassed bond strength of polypropylene base links and soft thermoplastic elastomer on top. The SuperGrip top combines a large contact surface with effective removal of dirt or wear debris.

TYPICAL APPLICATIONS

1000 Belts can be used for general conveying applications for a wide variety of products. They are also suitable for all medium to large sized packed products, e.g. boxes, bags, crates, trays, etc. and for larger (pieces of) unpacked products such as bread, pizza, bacon, fish, meat and chicken. Furthermore they can be applied for light duty elevators when equipped with flights and for inclining boxed or packed products when equipped with SuperGrip.

AND...

The belts will be supplied in standard lengths of 10 feet (3.048 m).

As a standard, all 1000 belts are equipped with



TRAYS WITH CANS SMOOTHLY CONVEYED ON 1000 SUPERGRIP



POSITRACK GUIDING LUGS FOR FG



SUPERGRIP FOR INCLINE



FLIGHT FOR ELEVATING



ROD RETENTION BY EASY CLIPS

1000 FT/FG/SG BELTS

Belt material	Colour	Rod material	Working load	Temperature range (°C)		Belt weight		Backflex radius (min)
				dry	wet	kg/m ²		
						N/m		FT
WLA Polyethylene	White	Polyethylene	5000	-70 up to +35		4.6	3.7	25.4
BLA Polyethylene	Blue	Polyethylene	5000	-70 up to +35		4.6	3.7	
WHA Polypropylene	White	Polypropylene	11000	4 up to 104		4.3	3.5	
WSA Acetal	White	Polypropylene	22000	4 up to 80	4 up to 65	6.5	5.4	
BSA Acetal	Blue	Polypropylene	22000	4 up to 80	4 up to 65	6.5	5.4	

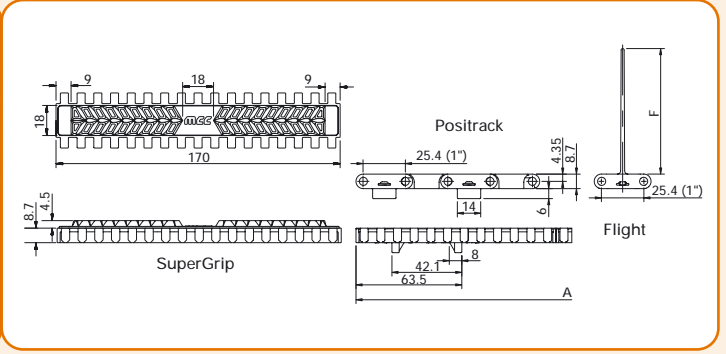
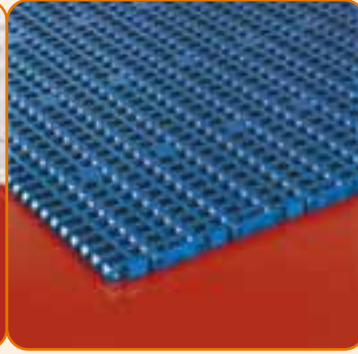
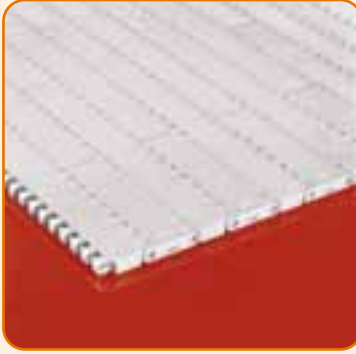

SPROCKETS FOR 1000 SERIES

Number of teeth	Bore	Code number	Pitch diameter E	Outside diameter F	Hub width A
	B				
12	40 x 40	893.02.21	98.1	96.5	20.0
18	40 x 40	893.08.21	146.3	145.9	20.0
18	60 x 60	893.08.28	146.3	145.9	30.0
20	40 x 40	893.09.21	162.4	161.7	20.0
20	60 x 60	893.09.28	162.4	161.7	30.0

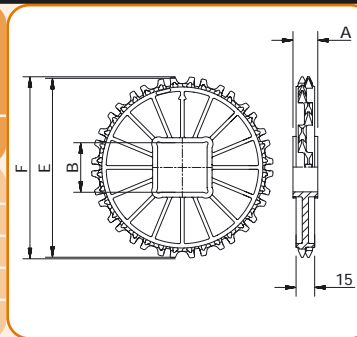

All sprockets are one-piece, moulded and made of blue acetal. For most applications, 1 sprocket is recommended for every 85 mm belt width. Other versions, such as split sprockets, are also available.

HOW TO ORDER THIS BELT?

To make a description of the belt you require, please choose from the options listed in the 2nd column of the table below for every part:

Material	WLA BLA WHA WSA BSA	See table above and page 19
Belt type	1000 FT 1000 FTDP 1000 FG 1000 FGDP 1000 SG	FT for Flat Top Double Positrack guiding lugs on one side of the belt (only in WSA material) FG for Flush Grid Double Positrack guiding lugs on one side of the belt (only in WSA material) SG for SuperGrip (only in WHA material)
Width (A)	KM-.. (in mm)	Standard nominal widths of these belts begin at 85 mm, with 85 mm increments, or optionally 5 mm; belts with flights have a minimal width of 130 mm with 10 mm increments
Height of flights	F3 H.. (in mm)	For standard height of 3" (76.2 mm) For special heights
Pitch between flights	T..P	Flights on every .. th row (must always correspond to an even number of rows)
Flight side-indent	N.. (in mm)	Minimal side-indent (distance from the side of the belt to the flight) 40 mm with 5 mm increments

For example:

- WSA 1000 FGDP KM-430 H50 T6P N45 is a 1000 Flush Grid belt with Double Positrack, made of white acetal with Microban, special width 430 mm, special 50 mm high flights on every 6th row at 45 mm from the sides.

If the belt or sprocket (material, size, bore) you require is not described in this table, please send us a detailed drawing or ask our Technical Support department for advice.

1010 SERIES

1010 Series 1 inch pitch modular belts are designed to meet the increasing demand from food processing industry for improved hygiene and better cleanable products. The 1010 series is an all round belt suitable for all segments of the food industry. It is available in a 1015 Solid Top execution with a fully closed surface.



1015 SOLID TOP BELT FOR FISH APPLICATIONS

ADVANTAGES

✚ Excellent cleanability

When turning over a roller the hinges open, exposing a large amount of the pin surface, offering excellent possibilities to clean. The hinge design is extremely open and accessible. This means a large surface of the pin and the inside of the hinge can be cleaned effectively. The bottom of the module is curved, improving drainage and reducing the drying time of the chain after cleaning.

✚ Easy pin retention

A moulded pin with T-shaped head retains the pin in a specially designed eccentric outer hinge eye. This makes the belt easy to operate for maintenance and cleaning.

✚ Less adjacent surfaces

The belt is supplied mould to width up to 24 inch, avoiding adjacent surfaces between the modules. The hinges are 1/2 inch wide, reducing the number of adjacent surfaces.

✚ Hygienic sprockets

Fully closed machined sprockets are ideal for cleaning. Due to the double teeth rows the sprockets are bi-directional and easy to position.

APPLICATIONS

The 1010-series is meant for light to medium duty applications. It can handle meat, seafood, fruits and salads after being cut or processed otherwise. The belt is also suitable for direct food contact after frying, cooking, baking, freezing, marinating, washing etc. In high risk areas requiring highest hygiene demands, the 1015 can also be used for (semi-) packed products. Obviously in these critical areas cleanability is very important.

AND...

As a standard 1010 series belts are equipped with



PEACHES SMOOTHLY CONVEYED ON 1010 SERIES



EASY ROD RETENTION

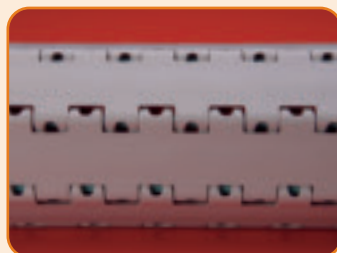

EXCELLENT PIN EXPOSURE



WELL ACCESSIBLE HINGE DESIGN FOR EASY CLEANING

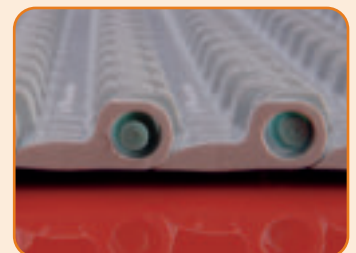

CURVED BOTTOM SURFACE FOR PERFECT DRAINAGE

1015 BELTS

Belt material	Colour	Rod material	Working load	Temperature range (°C)		Belt weight	Backflex radius (min)
			N/m	dry	wet	kg/m ²	mm
WLA Polyethylene	White	Polyethylene	5000	-70 up to +35		4.8	40.0
BLA Polyethylene	Blue						
WHA Polypropylene	White	Polypropylene	6000	4 up to 104		4.4	
BHA Polypropylene	Blue						
WSA Acetal	White	Polyester (PBT)	12000	-40 up to 80	up to 50	7.0	
BSA Acetal	Blue						

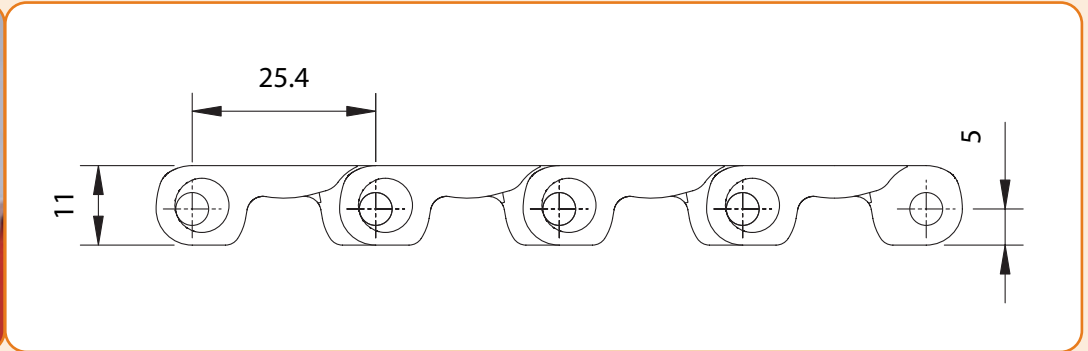
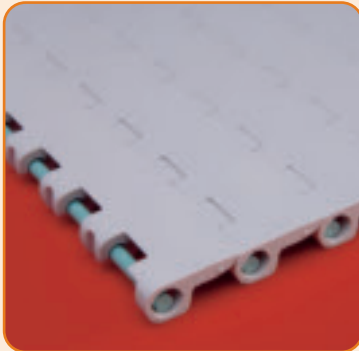

SPROCKETS FOR 1010 SERIES

Number of teeth	Bore	Code number	Pitch diameter	Outside diameter	Hub width A
	B		E	F	
		mm	mm	mm	mm
10	40 x 40	897.10.35	82.2	82.7	25.4
10	Ø40	897.10.33			
12	40 x 40	897.10.44	98.1	98.9	
12	Ø40	897.10.42			
16	40 x 40	897.10.73	130.2	131.5	
16	Ø40	897.10.71			
18	40 x 40	897.10.88	146.3	147.8	
18	Ø40	897.10.86			
20	40 x 40	897.11.03	162.4	164.0	
20	Ø40	897.11.01			

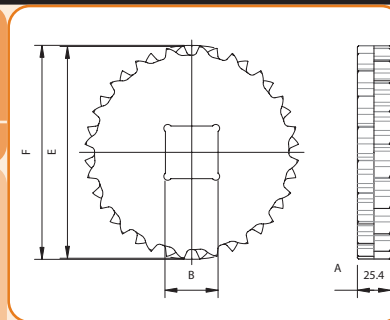

All sprockets are one-piece, machined and made of white polyethylene. Other bore sizes and tooth numbers are available. For the required number of sprockets please check the Rexnord calculation programme.

HOW TO ORDER THIS BELT?

To make a description of the belt you require, please choose from the options listed in the 2nd column of the table below for every part:

Material	WLA BLA WHA BHA WSA BSA	See table above and page 19
Belt type	1015	
Width	K.. (in inches)	

For example:

- BHA 1015 K20 is a 1015 Solid Top belt made of blue polypropylene, width 20 inch.

6391/6392 SERIES

6391 And 6392 series hybrid belts combine the strength of stainless steel rods and tension plates with the good product support and drainage of moulded plastic links. The belt links are available in two shapes: the 6391 has unique small holes that offer good drainage, while still supporting the smallest of products. The 6392 has larger apertures and is preferable for applications with an increased risk of clogging up of the holes in the belt links. The 6391 and 6392 belts have a 50 mm pitch. The open area of the 6391 is 26%, of the 6392 it is 48%.



VEGETABLES SMOOTHLY CONVEYED ON 6392

BENEFITS

High strength and good dimensional stability

Because of the stainless steel pins and the addition of stainless steel tension plates, the belt maintains its geometry, even at high temperatures. No large pitch elongation occurs due to thermal expansion and thus the catenary geometry does not change during operation.

Completely smooth edges

Unlike conventional hybrid belts, the 6391 and 6392 have completely flush edges without any protruding parts such as nuts, rods and washers. Because of this there is no risk of belt edges catching up in the conveyor.

Minimal adherence

The cross sections of the belt links are diamond-shaped so that the contact area with the product is minimal. Therefore chances of the product adhering to the belt are minimised. Also the sizes of the holes in the plastic links make them suitable for even the smallest products.

Long life

Because of the stainless steel skeleton, this belt has a long life even in harsh conditions like blanchers or cookers.

TYPICAL APPLICATIONS

6391/6392 Belts can be used for blanchers, cookers and coolers and for washers of vegetables (mushrooms, spinach, potatoes, tomatoes, etc.) and fruit (peaches, cherries, etc.) and different kinds of pasta. They are also suitable for medium duty elevators for applications where a large drainage capacity is required.

AND...

The belts will be supplied in any desired length. Tension plates can be added in any needed quantity.



6391 FLUSH GRID BELT FOR BLANCHING APPLICATIONS



FLIGHT FOR ELEVATING



SIDE GUARDS



TENSION PLATES

6391/6392 FG BELTS

Belt material	Colour	Rod and tension plates material	Working load N	Temperature range (°C)		Belt weight kg/m ²	Backflex radius (min) mm
				dry	wet		
WLT Polyethylene	White	Stainless steel (AISI 304)	1500 per row of tension plates	-70 up to +35		9 + 0.3 per row of tension plates per m belt width	50.0
BHT Polypropylene	Blue			4 up to 104			
WHT Polypropylene	White			4 up to 104			

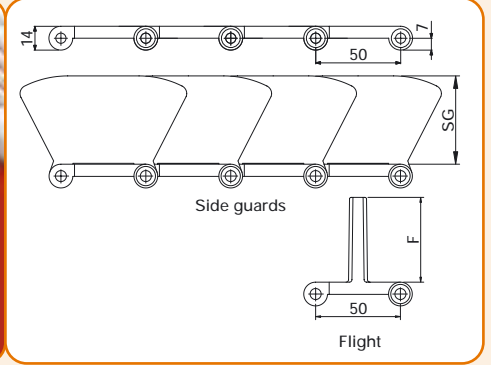

SPROCKETS FOR 6391/6392 SERIES

Number of teeth	Bore	Code number	Pitch diameter E mm	Outside diameter F mm	Hub width A mm
	B				
	mm				
8	40 x 40	16390638922	130.6	120.7	60.0
10	40 x 40	16390638932	161.8	153.9	
12	40 x 40	16390638942	193.2	186.6	
16	40 x 40	16390638952	256.3	251.4	

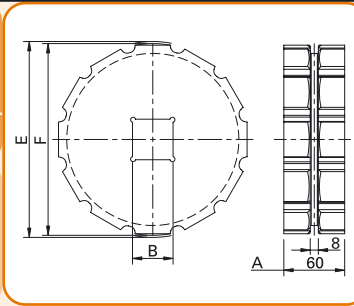

All sprockets are one-piece, machined and made of white polyethylene. Machined split sprockets are also available. For loads up to 100% of the maximum working load the sprockets should be placed at a centre distance of 75 mm. For loads up to 50% of the maximum working load the sprockets should be placed at a centre distance of 150 mm. Sprockets should be placed at the position of the tension plates.

HOW TO ORDER THIS BELT?

To make a description of the belt you require, please choose from the options listed in the 2nd column of the table below for every part:

Material	WLT BHT WHT	See table above and page 19
Belt type	6391 FG 6392 FG	
Number of tension plates	R..	Number of rows of tension plates over the total width of the belt; you can add a row of tension plates at each 75 mm
Width	KM-.. (in mm)	Standard nominal widths of these belts begin at 75 mm, with 75 mm increments or optionally 25 mm. Add 5 mm to the total width for every row of tension plates
Height of flights	F15 F50 F142 H.. (in mm)	For standard height of 15 mm For standard height of 50 mm For standard height of 142 mm For special heights
Pitch between flights	T..P	Flights on every .. th row
Flight side-indent	N.. (in mm)	Minimal side-indent 50 mm with 25 mm increments; side-indent is the distance from the side of the belt to the side of the flight. Side guards reduce the side indent by 13 mm
Height of side guards	SG52	52 mm

For example:

- WLT 6392 FG R2 KM-235 H30 T4P N50 is a 6392 Flush Grid belt made of white polyethylene, 2 rows of tension plates, total width 235 mm (3x75 + 2x5), special 30 mm high flights on every 4th row at 50 mm from the sides; no side guards.
- WHT 6391 FG R3 KM-465 F50 T6P N50 SG52 is a 6391 Flush Grid belt made of white polypropylene, 3 rows of tension plates, total width 465 mm (6x75 + 3x5), 50 mm high flights on every 6th row at 50 mm from the sides and 52 mm high side guards.

If the belt or sprocket (material, size, bore) you require is not described in this table, please ask our Technical Support for advice.

2010 SERIES

2010 Series belts have specially been designed for conveyance of meat, poultry, vegetables and fruit, but can also be used for a wide variety of general handling and packaging applications. The 2010 belt has a 2 inch pitch. The hinge eyes have the best possible accessibility during cleaning operations: a large part of the pins of the belt is visible and the special channel of the hinge eye offer optimum cleaning possibilities. The 2015 Solid Top has a fully closed surface, whilst the 2016 Perforated Top has slotted holes for drainage of water or air flow; on the 2011 Textured Top small nubs on the belt prevent sticking of soft or frozen products.



2015 SOLID TOP BELT FOR POULTRY APPLICATIONS

BENEFITS

✚ Good cleanability

The modules of the 2010 belt are flush all around and do not have any closed or hidden pockets. Especially the large open area between the rows of hinge eyes underneath the belt offer very good accessibility for cleaning. The rod retention area is very easy to clean and because of the absence of rims or hidden areas there is no risk of dirt and debris accumulating.

✚ Easy installation and maintenance

This belt is very easy to assemble or disassemble, due to the integrated locking system. By using just a screwdriver the rod retention finger can be positioned in either the 'locked' or the 'unlocked' position.

✚ Extended hinge eyes

The extended hinge eyes underneath the belt provide a large footprint, thus reducing contact pressure and wear. The connection of the hinge eyes with the top plate is very rigid, giving the belt excellent impact resistance. The large rod diameter also means less pressure and less wear in the hinges.

✚ Strong, bi-directional drive

The design of the sprocket and the belt has been optimised to ensure an excellent drive, up to the maximum working load of the belt during the whole life of the belt. The machined sprockets have excellent strength and cleanability.

APPLICATIONS

2010 Belts can be used for meat and poultry handling applications in deboning and trimming lines, for elevators and for the general handling of meat and poultry. They are very suitable for heavy-duty elevators where no drainage is required, for example in the meat, poultry, confectionery and salad industry. They can also be applied for sliced or cut products where a closed surface is required to prevent product loss.

AND...

The belts will be supplied in any desired length depending on the exact design of the belt.

As a standard, all 2010 series belts are equipped with



CONFECTIONERY SMOOTHLY CONVEYED ON 2010 SERIES



STRAIGHT FLIGHT FOR ELEVATING



CURVED RIBBED FLIGHT



SIDE GUARDS



ROD RETENTION BY INTEGRATED LOCKING SYSTEM

2015/2016/2011 BELTS

Belt material	Colour	Rod material	Working load	Temperature range (°C)		Belt weight	Backflex radius (min)
				dry	wet		
			N/m			kg/m ²	mm
WLA Polyethylene	White	Polyethylene	7500	-70 up to +35		9.5	87.0
BLA Polyethylene	Blue	Polyethylene	7500	-70 up to +35		9.5	
WHA Polypropylene	White	Polypropylene	15000	4 up to 104		8.9	
WSA Acetal	White	Polypropylene	20000	4 up to 80	4 up to 65	13.6	
BSA Acetal	Blue	Polypropylene	20000	4 up to 80	4 up to 65	13.6	

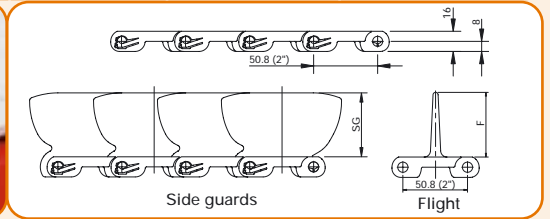

SPROCKETS FOR 2010 SERIES

Number of teeth	Bore	Code number	Pitch diameter	Outside diameter	Hub width
	B		E	F	
6*	40 x 40	897.20.23	101.6	87.0	32.9
8	40 x 40	897.20.04	132.8	121.0	
10	40 x 40	897.20.07	164.4	154.0	
12	40 x 40	897.20.26	196.3	188.0	

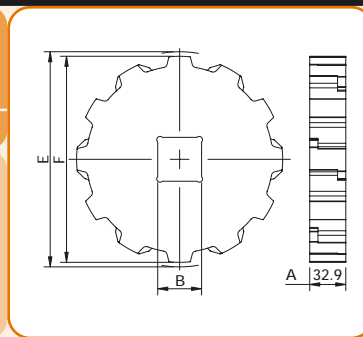

* 6 tooth sprockets are recommended as idlers only.

All sprockets are one-piece and made of white polyethylene. Many other bore sizes and tooth numbers are available. For belt loads <10% the distance between the sprockets is 6", 10-30%, it is 4" and >30% it is 3".

HOW TO ORDER THIS BELT?

To make a description of the belt you require, please choose from the options listed in the 2nd column of the table below for every part:

Material	WLA BLA WHA WSA BSA	See table above and page 19
Belt type	2015 2016 2011	Solid Top Perforated Top Textured Top
Width	KI... (in inches)	Standard nominal widths begin at 6" (152.4 mm), with 2" (50.8 mm) increments, or optionally 2/3" (16.8 mm). Belts with flights have a minimal width of 8" (203.2 mm)
Height of flights	F6 F5 F4 F3 F2 F1 H.. (in mm) C6 C4 RF4 or RF3 or RF2 RC6 RC4	Straight flight with standard height of 6" (152.4 mm) Straight flight with standard height of 5" (127.0 mm) Straight flight with standard height of 4" (101.6 mm) Straight flight with standard height of 3" (76.2 mm) Straight flight with standard height of 2" (50.8 mm) Straight flight with standard height of 1" (25.4 mm) Straight flight with special height Curved flight with standard height of 6" (152.4 mm) Curved flight with standard height of 4" (101.6 mm) Ribbed straight flight with standard height of 4" (101.6 mm) or 3" (76.2 mm) or 2" (50.8 mm) Ribbed curved flight with standard height of 6" (152.4 mm) Ribbed curved flight with standard height of 4" (101.6 mm)
Pitch between flights	T..P	Flights on every .. th row
Flight side-indent	N.. (in inches)	Minimal side-indent (the distance from the side of the belt to the flight) 2" with increments of 2/3" (16.8 mm); side guards are situated at 1/3" from the flight, reducing the indent by 2/3"
Height of side guards	SG.. (in inches)	Standard heights 2" (SG2, 50.8 mm), 3" (SG3, 76.2 mm), 4" (SG4, 101.6 mm)

If the belt or sprocket (material, size, bore) you require is not described in this table, please ask our Technical Support for advice.

5998 SERIES

5998 Series Flush Grid belts are suitable for most efficient air and water flow during freezing, blanching, heating and washing of many sorts of large fruits and vegetables. Flights and side guards are available for elevating applications. The 5998 belt has a 2 1/4 inch pitch. The open area is 45%.



5998 FLUSH GRID BELT FOR FRUIT APPLICATIONS

BENEFITS

✚ Good cleanability

The modules of the 5998 have a large open area. The pockets for drive sprockets are opened up from the top, so that no dirt can build up. The rod retention system is entirely open to facilitate cleaning.

✚ Easy installation and maintenance

This belt is very easy to assemble due to the plugs looking like golf tees. The plugs and rods can be disassembled without being damaged.

✚ Huge strength

Due to the large rod diameter and the large amount of hinge eyes the belt strength is unrivalled in food applications. The large rod diameter also reduces pressure and wear in the hinges.

✚ Strong, bi-directional drive

The tooth profile and tooth height together with the large pockets in the belt links make the sprocket engagement very robust and fit for the harshest possible conditions in bulk food handling or abrasive situations. For very high temperatures or applications requiring strong chemical resistance special sprockets are available.

APPLICATIONS

5998 Belts can be used for heavy-duty applications that require optimum drainage or air-flow in combination with large products such as carrots, apples, tomatoes etc. They are specially suitable for heavy-duty elevators carrying large or heavy products from water baths, such as tomatoes, apples, onions, cabbages and other fruits and vegetables.

AND...

The belts will be supplied in any desired length depending on the exact design of the belt.



VEGETABLES SMOOTHLY CONVEYED ON 5998



FLIGHT FOR ELEVATING



SIDE GUARDS



ROD RETENTION BY EASY PLUGS

5998 FG BELTS

Belt material	Colour	Rod material	Working load	Temperature range (°C)		Belt weight	Backflex radius (min)
				dry	wet		
			N/m			kg/m ²	mm
WLT Polyethylene	White	Polyethylene	23300	-70 up to +35		8.9	57.0
BLT Polyethylene	Blue	Polyethylene	23300	-70 up to +35		8.9	
WHT Polypropylene	White	Polypropylene	35000	4 up to 104		8.4	

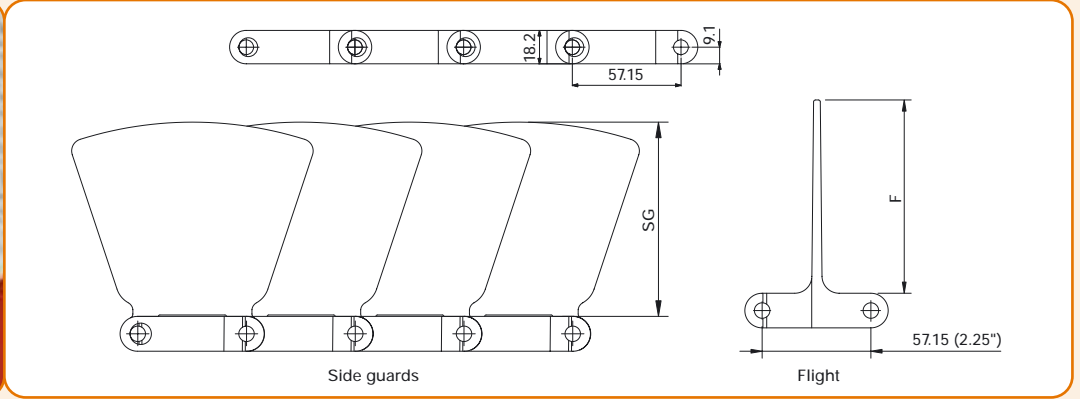

SPROCKETS FOR 5998 SERIES

Number of teeth	Bore	Code number	Pitch diameter E	Outside diameter F	Hub width A
	B				
	mm		mm	mm	mm
7	40 x 40	114-821-11	131.7	125.5	47.7
9	40 x 40	114-884-11	167.1	164.1	

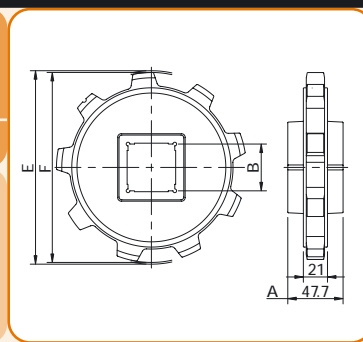

All sprockets are one-piece, moulded and made of black acetal.
For most applications, 1 sprocket is recommended for every 6" (152.4 mm) belt width.

HOW TO ORDER THIS BELT?

To make a description of the belt you require, please choose from the options listed in the 2nd column of the table below for every part:

Material	WLT BLT WHT	See table above and page 19
Belt type	5998 FG	
Width	KI.. (in inches)	Standard nominal widths begin at 6" (152.4 mm), with 6" increments, or optionally 1/2" (12.7 mm)
Height of flights	F4 H.. (in mm)	for standard height of 4" (101.6 mm) for special heights
Pitch between flights	T..P	Flights on every .. th row
Flight side-indent	N.. (in inches)	Minimal side-indent 2" (50.8 mm) with 1/2" (12.8 mm) increments; side-indent is the distance from the side of the belt to the side of the flight. NOTE: side guards are situated at 1/2" from the flight, reducing the indent by 1" (25.4 mm)
Height of side guards	SG4	Standard height 4" (101.6 mm)

For example:

- WLT 5998 FG KI-18 F4 T4P N2 SG4 is a 5998 Flush Grid belt made of white polyethylene, width 18", 4" high flights on every 4th row, at 2" from the sides, and 4" high side guards.
- WHT 5998 FG KI-12 1/2 H75 T6P N2 1/2 SG4 is a 5998 Flush Grid belt made of white polypropylene, special width 12 1/2", 75 mm high flights on every 6th row, at 2 1/2" from the sides, and 4" high side guards.

If the belt or sprocket (size, bore or material) you require is not described in this table, please send us a detailed drawing or ask our Technical Support department for advice.

1221 SERIES

1221 Series bucket elevator chains offer an alternative solution for elevator conveyors next to modular belts, especially when the conveyor design can be fully standardised and when the application involves a lot of abrasion.

The 1221 belts have a 130 mm pitch. The 1221 RC has a closed surface and the 1221 ROT has a 16% open area.



1221 RC BELT FOR FRUIT APPLICATIONS

BENEFITS

✚ Long life

The large rollers positioned at the side of the belts provide a rolling friction as opposed to sliding friction, so wear is reduced.

✚ Enormous strength

Unlike certain bucket elevator chains the load is not carried by the plastic buckets itself but by the stainless steel rods and the stainless steel tension plates that connect the buckets.

✚ Steep elevating angles

The 1221 bucket elevator chain can be used for steep elevating angles, up to 55°.

✚ Easy cleaning

The design of the 1221 chain itself and of the conveyor for this chain provides good accessibility for cleaning. Because of the bucket geometry, the product will not get stuck in or adhere to the chain.

APPLICATIONS

1221 Belts can be used for inclined conveyors requiring steep angles in combination with maximum capacity. They can be applied for products that require drainage, such as fruit and vegetables picked from a water bath and for products where product loss must be prevented, such as sliced and cut fruits with juice, confectionery, meat carried with fat and juices.

AND...

The 1221 RC and 1221 ROT belts will be supplied in standard lengths of 2.08 meters (16 buckets).

1221 RC/ 1221 ROT BELTS

Bucket material	Colour	Sidebar and rod material	Working load kg/bucket	Temperature range (°C)		Belt weight kg/m	Backflex radius (min) mm
				dry	wet		
WHT Polypropylene	White	Stainless steel	2.5	4 up to 80		7.9	350.0

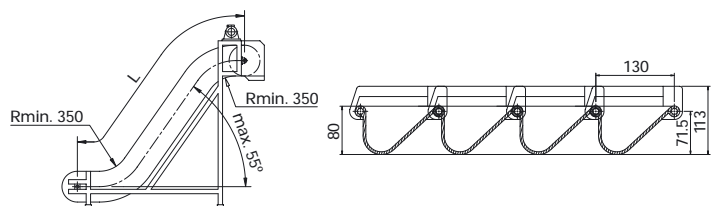

The standard length is 16 pitches (2.08 m). The width of the buckets is 392 mm, or 509 mm including rollers. The recommended speed is maximum 30 m/min. The bucket capacity is 1724 cm³. Ask our Technical Support for detailed information.

SPROCKETS FOR 1221 SERIES

Number of teeth	Bore	Code number	Pitch diameter E mm	Outside diameter F mm	Hub width A mm
	B mm				
7	ø20	11221600966	299.65	320.0	92.5

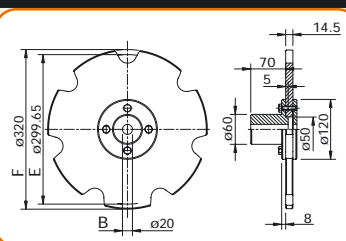

This sprocket is one-piece, machined, pre-bored and made of stainless steel AISI 303 (hub)/304 (sprocket). Other materials, bores and number of teeth will be tailor-made. 2 Sprockets are required for the drive shaft.

HOW TO ORDER THIS BELT?
Please choose from the two available types:

WHT 1221 RC
WHT 1221 ROT

closed buckets
open buckets

Different applications in the food industry require different materials. The following materials are being offered in this food programme:

BELTS

Polypropylene

Polypropylene has excellent material properties for general applications. It excels in high temperature applications and it is often the most economic choice. Depending on the type of belt, polypropylene belts in this programme are made out of one of the following two materials:

WHA: white polypropylene with Microban antibacterial protection
WHT: white polypropylene
BHT: blue polypropylene

As a standard, polypropylene belts are equipped with polypropylene rods. For applications with high speed (>30 m/min), with high load or requiring special abrasion resistance most belt types can be fitted with special rods.

Typical applications: blanchers, warmer and cooler applications; general conveying.

Polyethylene

Polyethylene excels in low temperature applications and also has a high impact resistance. Polyethylene is remarkable for its good contact release of poultry. Depending on the type of belt, polyethylene belts in this programme are made out of one of the following materials:

WLA: white polyethylene with Microban antibacterial protection
BLA: blue polyethylene with Microban antibacterial protection
WLT: white polyethylene
BLT: blue polyethylene

Polyethylene belts are equipped with polyethylene rods.

Typical applications: heavy pieces of meat or meat with protruding bones falling on top of the belt; freezer in- and outfeeds; freezing tunnels; general chicken and fish handling.

Acetal

Acetal is the strongest material in the programme. It has the hardest surface, which makes it suitable for direct cutting on the surface of the belt. Its performance in sliding contacts with high pressure and high speeds are superior. It also has an intrinsic high abrasion resistance. Depending on the type of belt, the polyacetal belts in this programme are made out of one of the following materials:

WSA: white acetal with Microban antibacterial protection
BSA: blue acetal with Microban antibacterial protection

As a standard, acetal belts are equipped with polypropylene rods. For very high speeds or abrasive applications most belts can be fitted with special rods.

Typical applications: deboning or trimming lines where cutting takes place on the belt; fruit, vegetable and fish transport producing debris like sand, etc. such as in infeed washers; sideflexing belts that combine high load and high speed.

WEARSTRIP FOR FLEX BELTS:

MCC 3500: special lubricated polyamide for superior PV-rating (not FDA-approved). Colour: grey-black
MCC 3600: polyester based plastic for direct food contact (FDA-approved). Colour: white

MISCELLANEOUS

- The precise actual width of all belt types may slightly differ from nominal widths. Contact our Technical Support department for advice.
- Some cleaning agents may affect the properties of the material. For detailed info contact our Technical Support department, or your cleaning agent supplier.
- Solutions for drum drives have been developed in close co-operation with their suppliers. Ask Technical Support for more details.



Besides the belts and sprockets mentioned in this brochure, Rexnord can offer you a huge range of plastic and stainless steel chains, other modular belts, curves, split and classic sprockets, and other conveyor components, such as frame support and levelling elements, guide rails and bearing units. Ask for our specific documentation.

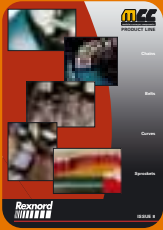

MCC BELTS AND CHAINS CATALOGUE



REX MATTOP CATALOGUE



REX TABLETOP CATALOGUE



MARBETT COMPONENTS CATALOGUE



MARBETT FEET CATALOGUE



MARBETT BEARINGS CATALOGUE



**REXNORD FLATTOP
EUROPE B.V.**
P.O. Box 112
2690 AC 's-Gravenzande
Netherlands
Phone: +31 (0)174-445111
Fax: +31 (0)174-445298

**RMCC DEUTSCHLAND
KETTE GmbH**
P.O.Box 10
35610 Aßlar-Werdorf
Germany
Phone: +49 (0)6443-83140
Fax: +49 (0)6443-831420

In the UK:
Phone: 0800-13528867 (toll-free)
Fax: +31 (0)174-445298

REXNORD-MARBETT S.r.L.
Via dell'Industria, 4
42015 Correggio (RE)
Italy
Phone: +39 0522-639333
Fax: +39 0522-637778

24 hrs Service
Only for urgent deliveries
Phone: +31 (0)174-445112
www.rexnordflattop.com
food@rexnord.com